

INSERT SPECIAL NUT IN BOTH ENDS OF PRE CUT HANDLE (THREADED HOLE TO MATCH LEVER ORIENTATION) AND PLACE END CAPS OVER END OF PRE CUT HANDLE. THE LENGTH OF THE HANDLE SHOULD BE LONG ENOUGH TO MOVE BACK AND FORTH SLIGHTLY ON THE CAPTURED SPECIAL NUTS, AFTER INSTALLING BOTH END CAPS ONTO THE SLIDE LEVERS. USE TWO 1/4" - 20 TPI X 5/16" LONG HEX HEAD CAP SCREWS TO FASTEN HANDLE IN PLACE BY PLACING SCREWS THROUGH THE END CAP HOLE AND SLIDE LEVER HOLE INTO THE SPECIAL NUTS. ENSURE THE HANDLE IS NOT FORCING THE SLIDE LEVERS OUTWARD TO PREVENT DAMAGE TO THE SLIDE MECHANISM. DO NOT OVERTIGHTEN SCREWS TO PREVENT DAMAGE TO THE PLASTIC LEVER COVERS. SOME TYPE OF THREAD LOCK SHOULD BE USED TO PREVENT BOLTS FROM BECOMING LOOSE OVER TIME DUE TO HANDLING AND VIBRATION.

EXAMPLE ADS-7650 DRAWER SLIDE WITH HANDLE INSTALLED WITH DRAWER SLIDE INVERTED TO SUPPORT POSSIBLE G-FORCE BOUNCE WEIGHT WHEN INSTALLED IN VEHICLES. DO NOT REMOVE PLASTIC FROM LEVER. NOTE IF LEVER PLASTIC IS REMOVED CUT LENGTH MUST BE INCREASED BY 3mm (0.118"). REMOVING PLASTIC IS "NOT" RECOMMENDED

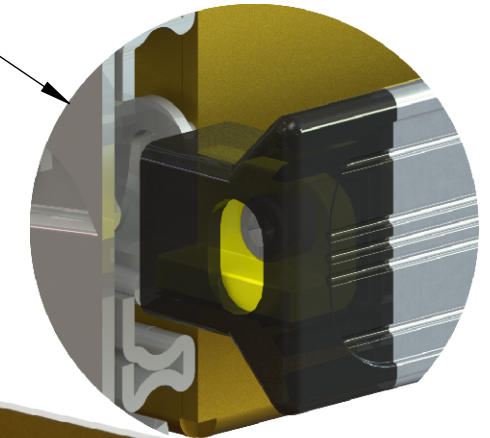

USE MEASURE DRAWER WIDTH MINUS 0.35" ~ 0.37" (CUT LENGTH) WITH YELLOW PLASTIC ON SLIDE LEVERS. ADD 3mm (0.118") TO ABOVE CUT LENGTH IF LEVER PLASTIC IS REMOVED

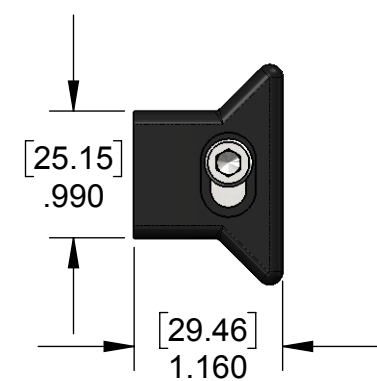
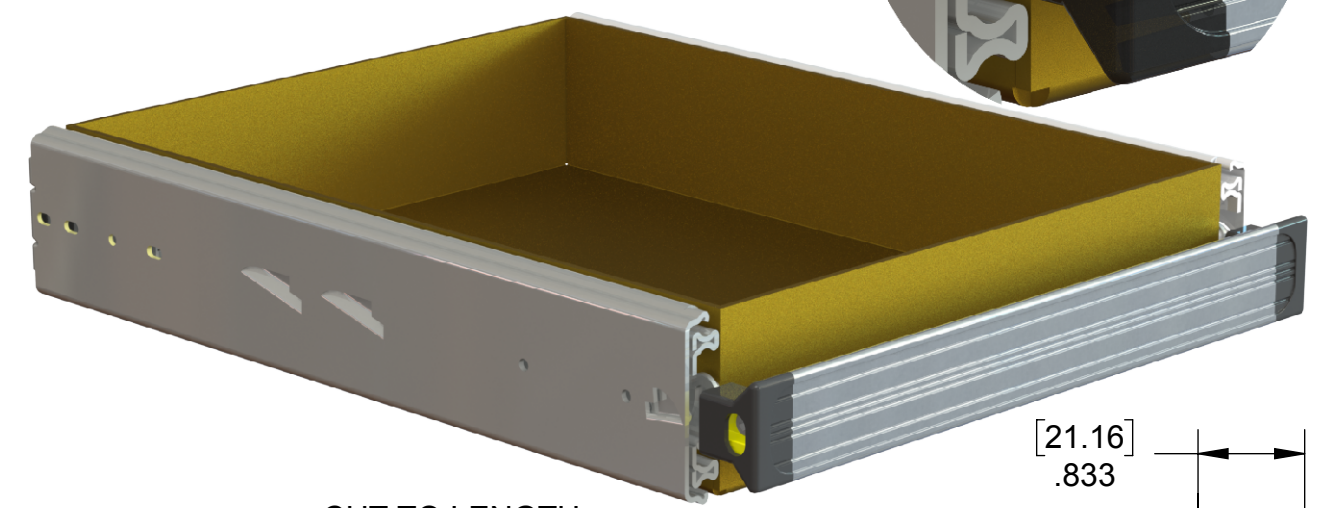
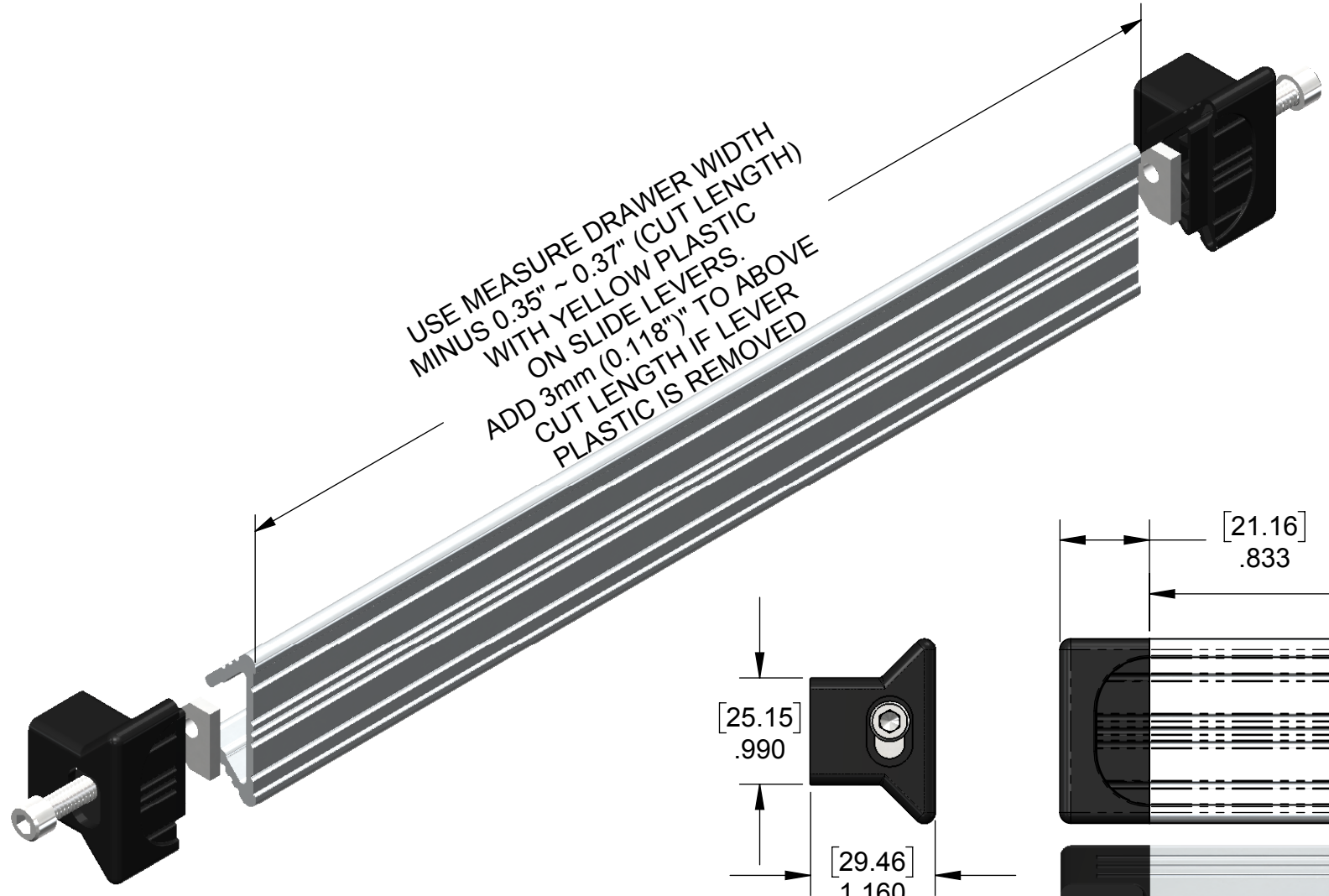

SLIDE LEVER BETWEEN BOLT HEAD AND END CAP. DO NOT OVERTIGHTEN

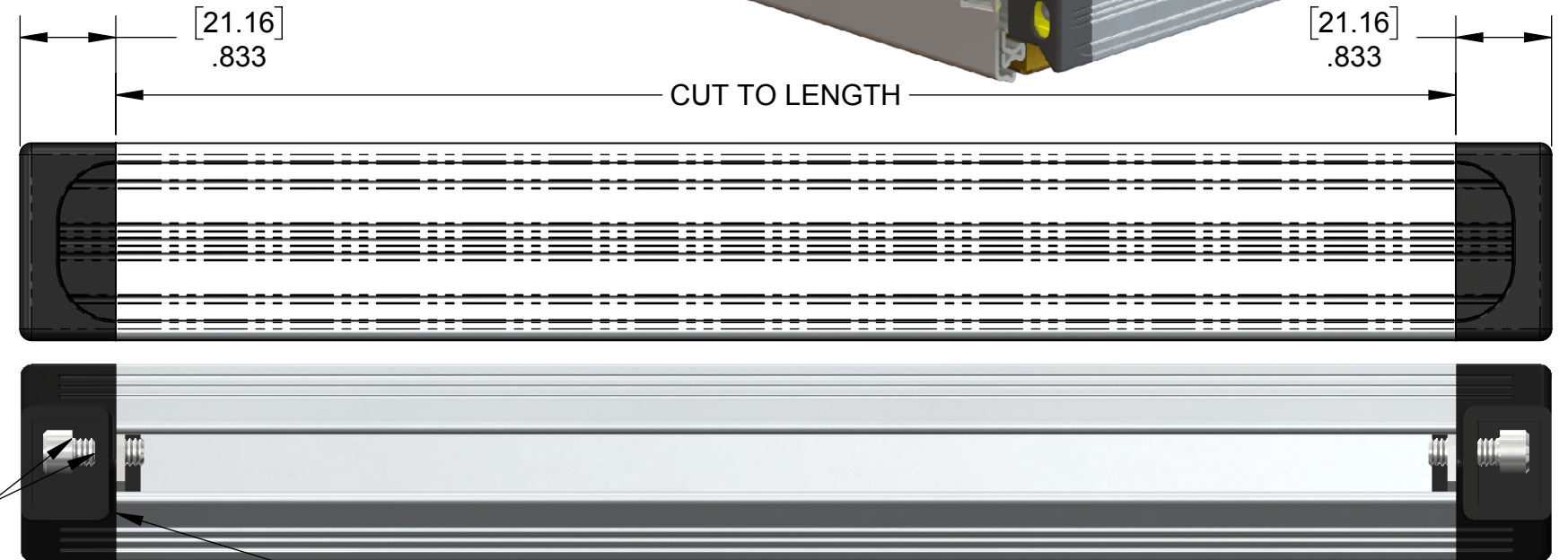

WITH END CAPS PLACED ONTO CUT HANDLE TEST FIT: IF TIGHT BETWEEN TWO MOUNTED SLIDE LEVERS PRIOR TO INSTALLING BOLTS, DO NOT ASSEMBLE UNTIL THERE IS NO OUTWARD FORCE ON LEVERS. SHORTEN EXTRUSION IF NEEDED. HANDLE SHOULD HAVE 0.010" TO 0.030" FREE PLAY BETWEEN END CAPS AFTER BOLTING IN PLACE.

**WEIGHT: TOTAL 0.49 LBS. ALUMINUM EXTRUSION = 0.40 LBS/FOOT**  
**MATERIAL: ALUMINUM/ZINC PLATED STEEL, NYLON END CAPS**  
**FINISH: CLEAR ANODIZE**

**DIMENSIONS MAY CHANGE WITHOUT NOTICE**



CREATION DATE: **11-17-2017**  
 CREATED BY: **rsmith**  
 THIRD ANGLE PROJECTION

FILE NAME: **Y\_DRP-S001-XXXXX-A01**  
 DESCRIPTION: **ADS-7650 ALUMINUM V-HANDLE ASSEMBLY**  
 PART NUMBER: **DRP-S001-XXXXX-A01**  
 REV **E**